

The logo for PELORUS, featuring the word "PELORUS" in a bold, white, sans-serif font. The letters are slightly shadowed, giving a 3D effect. The logo is positioned on a blue background that is part of a larger graphic consisting of overlapping chevron shapes in blue and yellow.

Enabling Technology in the Right Direction

Fiber Optical Monitoring Alarm System (FOMA) Specification



Fiber Optical Monitoring Alarm System (FOMA) Specification

Application features

This FOMA hardware is mutual related with its slotted devices and connected with its plug-in cards. The expansion type with its maintenance type is promoted greatly and protect client to the system investment effectively.

Guarantee to minimum the system conflict, keep the system stability and maintenance with integrity and unified. so that the maintenance cost is significantly reduced.

With 20 years OTDR professional production experience and design on demand in the system concept, we support client to streamline and increase the device at the best convenience

Support the rigorous privilege function to manage the remote control and data transfer functions.

The remote user-friendly graphical display as monitoring user interface in LAN and WAN.

The embedded Linux system: with its high security system to avoid the virus invasion crisis. With remote control the embedded image: to monitor data center operation and maintain equipment as well as training from the remote site.

Highly integrated structure design, which is easily to install and maintenance as well as easy operation.



FOMA System Structure C/S architecture

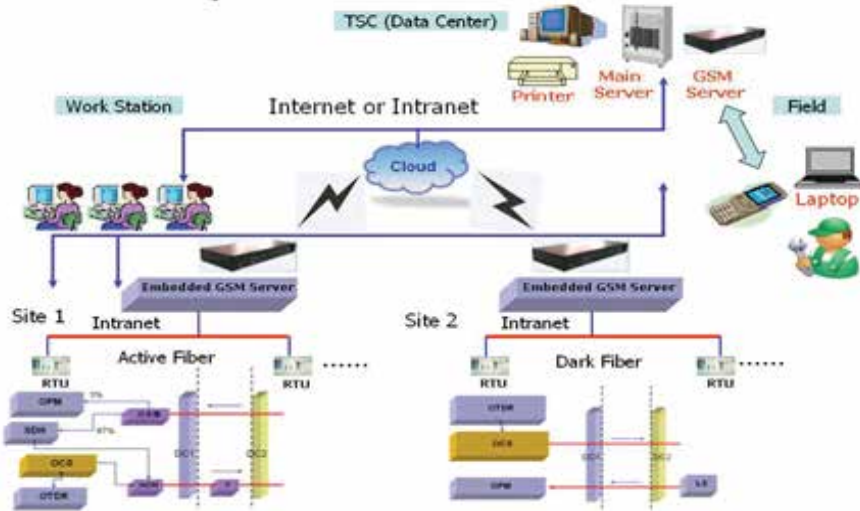

On-Line Monitoring

Combine test wavelength and operating wavelength in a fiber via WDM device. Use filter to filter out the test wavelength and let the operating wavelength pass. On line monitoring is to put a splitter in the route and separate 3~5% of the light to get the data.

On line monitoring diagram is as below:

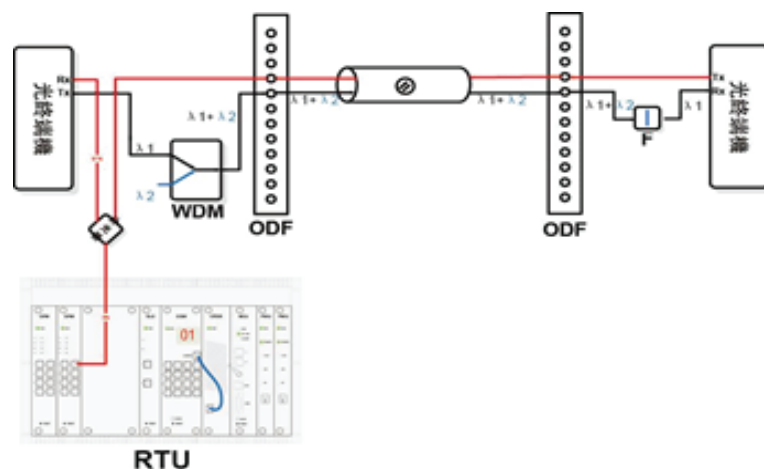

Off-Line Monitoring

Use the backup fiber. The fiber network system is easily to set up and maintain. Test wavelength can be the same with operating wavelength. Off line monitoring diagram is as below

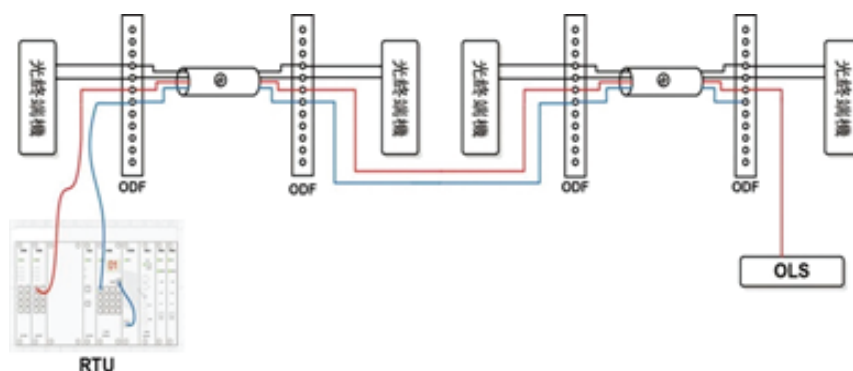



Technical Specification

| | | | | |
|-------------------|--|------------|-------------|------------|
| Item/Model | NLS | | | |
| Laser Type | FP Laser, Class I | | | |
| Wavelength | 1310nm±30nm | 1490nm±30m | 1550nm±30nm | 1625nm±30m |
| Spectral Width | ≤5nm | | | |
| Output Ports | 2 or 4 or 6 or 8 | | | |
| Output Power | ≥-3.0dBm or ≥-7.0dBm | | | |
| | | | | |
| Stability in 8Hr | ±0.1dB | | | |
| | | | | |
| Operating | 0 ~ 50°C, 5 to 95%RH (non condensing) | | | |
| Storage | -10 ~ 70°C, 5 to 95%RH(non-condensing) | | | |
| Optical Connector | FC or SC (PC), FC-APC or SC-APC | | | |



| S/N | Item | Content |
|-----|---------------------|--|
| 1. | Engineering Survey | Host room location and layout Host rack position and rack dimension space for equipment position in rack number of ODF rack in monitoring routing and equipment terminal length of jumper Power specifications, power cord Length Communications Networking |
| 2. | Rack installation | Rack installation depends on site survey (near ODF |
| 3. | Power Configuration | Location of the RTU rack with -48VDC Placed distal filter |
| 4. | RTU installation | RTU module installation, place RTU on a rack RTU external fiber jumper, wiring data record Equipment inspection before power supply, power on, and set the parameters Shop floor simulation monitoring, record setting |



| | | |
|-----|--|---|
| | | |
| | | parameters |
| 5. | monitor center installation | Server installation Monitor center software installation System integration and simulation test |
| 6. | Relay station line jumper | Monitoring optical fibers are connected to ODF According to the routing table in project plan, jumper cables, detailed records of jumper cables rack number, core number |
| 7. | Communications network construction, adjustment | Network planning Network cable layout Communication network connection |
| 8. | Data entry | Monitoring data entry |
| 9. | System testing | System adjustment and testing |
| 10. | System check and accept | According specification to check and accept |



| S/N | item | specification |
|-----|---|---|
| 1 | TSC | |
| 1.1 | information management software | |
| 1.2 | Monitor center server (mobile terminal) | <p>Performance indicators not less than Lenovo IdeaPad Y480N-ISE(H)</p> <p>Specification Intel™i7 processor i7-3630M 2.4 GHz</p> <p>4G DDR3 2GB GDDR5 Discrete graphics card</p> <p>;</p> <p>1TB SATA HD 1000Mbps Ethernet cards</p> <p>;</p> <p>Super DVD recorder Display 14.0" Display</p> |
| 1.3 | Monitor center server | <p>Lenovo T4980d ; :</p> <p>Intel i5-3470 3.2Ghz;6MB;4GB DDR3 ;</p> <p>1TB HD 7200RPM 1000Mbps Ethernet cards</p> <p>(); ;</p> <p>DVD recorder : 280WPower Display 20" Display</p> |
| 2 | RTU | <p>Modular design, all modules are plug-in for easy maintenance .RTU devices can be installed in a standard</p> |



| | | |
|-----|-----------------------|---|
| | | 19-inch rack. |
| 2.1 | RTU main frame | RTU main frame includes backplane bus and fan |
| 2.2 | MCU | Linux OS, Processor: ARM 9, Watch Dog monitor |
| 2.3 | Power module | -48V/DC double power (backup) |
| 2.4 | OTDR module | Wavelength 1625nm, 40dB |
| 2.5 | OCS module | 16Port |
| 2.6 | TF module | Pass Band : 1260~1565 nm |
| 2.7 | Laser source unit | 1Port, Wavelength 1550±20nm, (Optical output power >-5dBm |
| 3 | System engineer parts | |
| 3.1 | Optical patch cord | (Models can be used with equipment) |
| 3.2 | other engineer parts | Cables, installation materials to meet the project demand |



Pelorus Technologies Pvt. Ltd

7 C, Senior Estate, Near Sona Udyog, Parsi Panchayat Road, Andheri (East), Mumbai - 400 069. INDIA
P : +91-22-6689 4444 | F : +91 22 6689 4488 | Email: info@pelorus.in | pelorus.fibreoptics.in